

szakmai portfólió

Fekete Anna

TANULMÁNYOK

2012-2014

Magyar Képzőművészeti Egyetem, Budapest,
Látványtervező mesterképzés

2011-2012

Mimar Sinan Fine Arts University, Istambul,
Erasmus program

2009-2012

Magyar Képzőművészeti Egyetem, Budapest,
Látványtervező alapképzés

DÍJAK

2019_ Vidéki Színházak Fesztiválja,
Legjobb Látvány Díj

(Papp Janó, jelmeztervezővel közösen)

Jaroslav Hašek - Spiró György *Svejk* című produkció
díszlettervezéséért

2017_ Színkritikusok Díja, Legjobb díszlet
Günter Grass, *Bádogdob* című előadás
díszlettervezéséért

2022_ Az év díszlettervezője díj

Kosztolányi Dezső / Garai Judit, Néro című
produkció díszletéért

2024_ ASSISTEJ Magyar Központ Üveghegy díj
(A legkisebbeknek szóló legjobb előadás)

Julia Donaldson, *A legcsinosabb óriás* című
előadás rendezéséért (Bánki Gergellyel közösen)



Lázár Ervin: Berzsián és Dideki_
Budapest Bábszínház Díszlet, jelmez és báb
tervezés_2026

rendezte: Veres András
fényterv: Szondi György



Berzsián

Dideki

Frankensten_ Vígszínház
Díszlet_2026



Mary Shelley regénye alapján
a darabot írta:
Garai Judit, Hegymegi Máté
rendezte : Hegymegi Máté
jelmez: Kálmán Eszter
fényterv: Fridrick Gergely

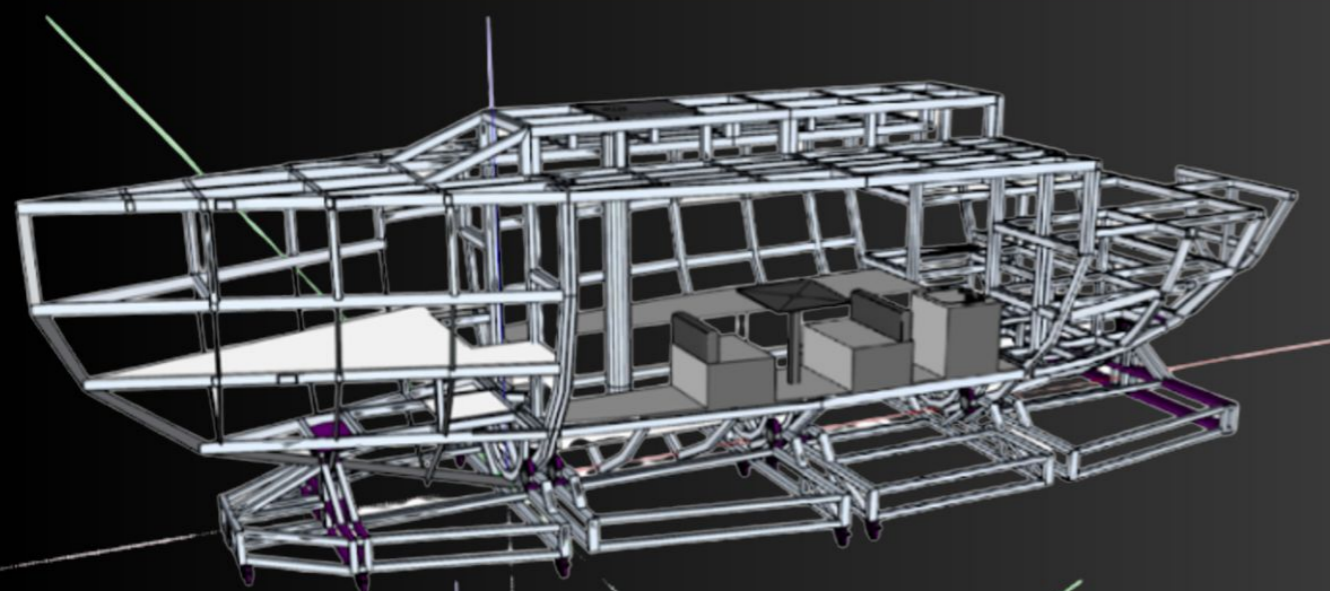
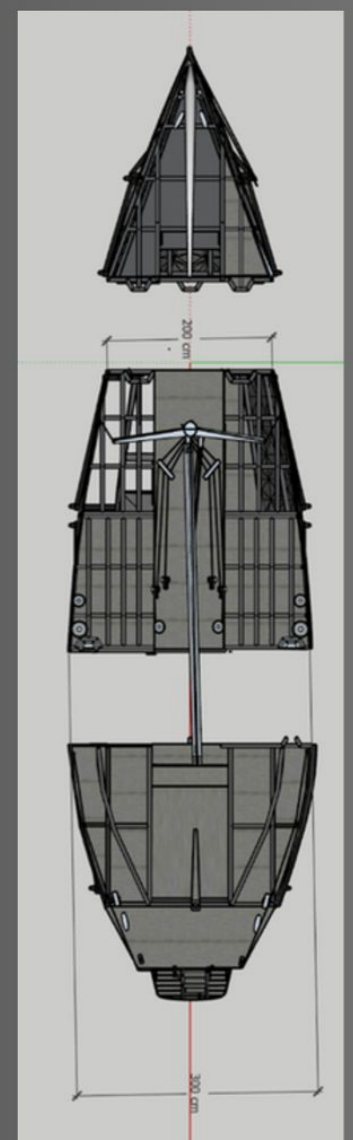
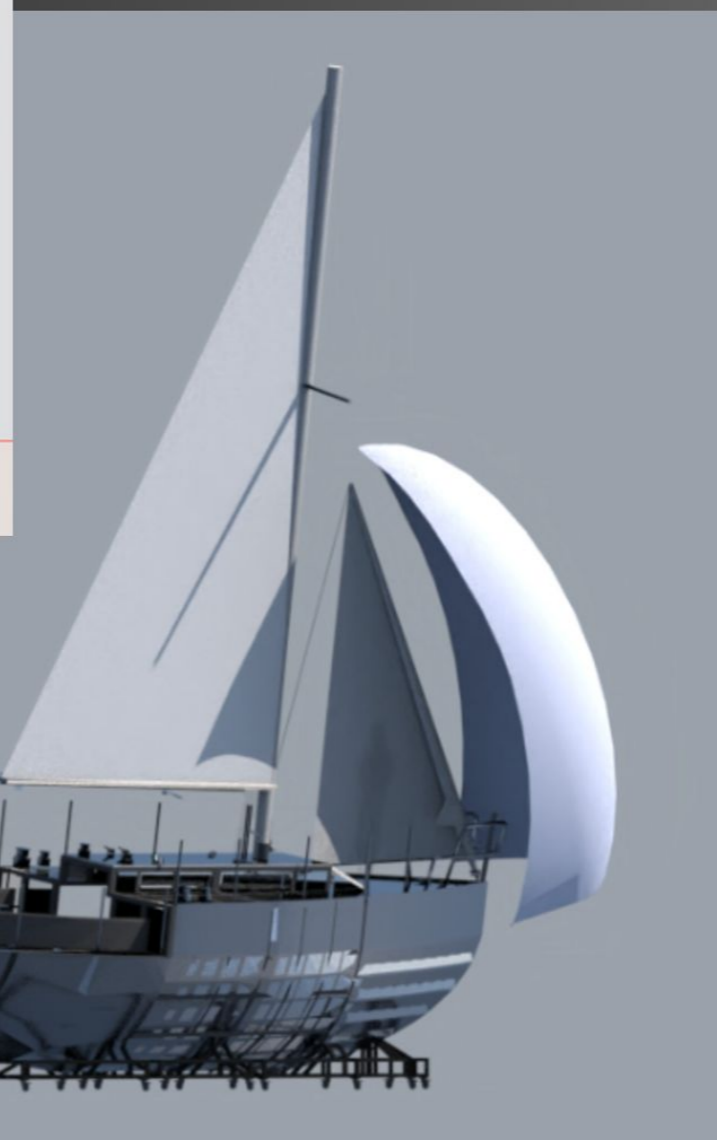
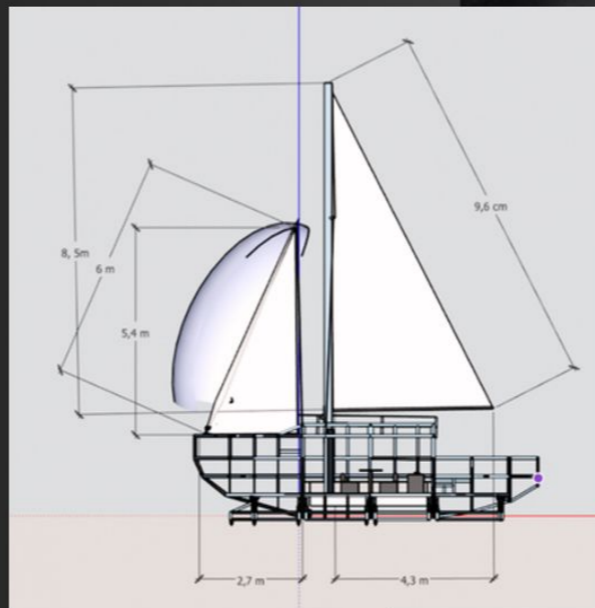
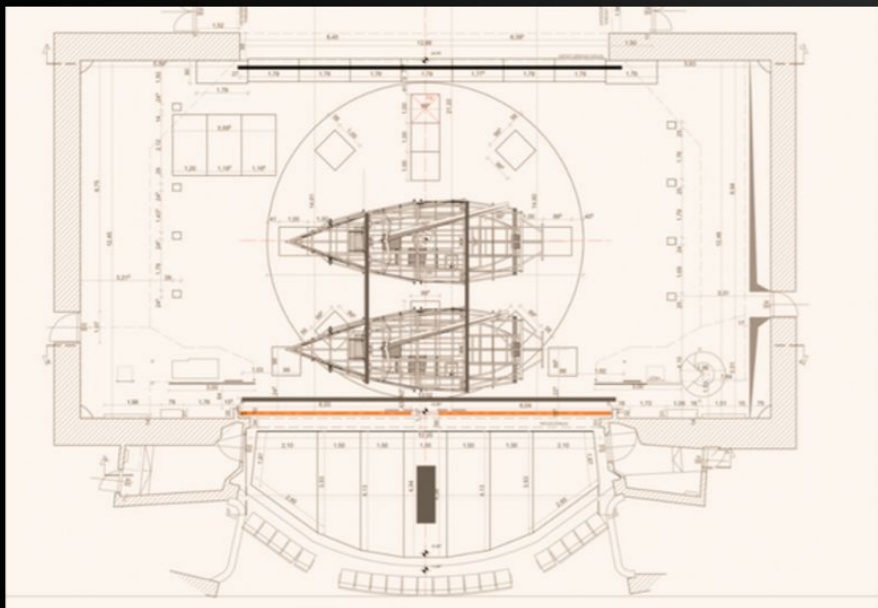

Nathan Ellis: Túl éles_ Marzibányi Téri Művelődési Központ díszlet_2025

rendezte: Horváth János Antal

jelmez: Kaszás Nina

fényterv: Mohácsi Júlia

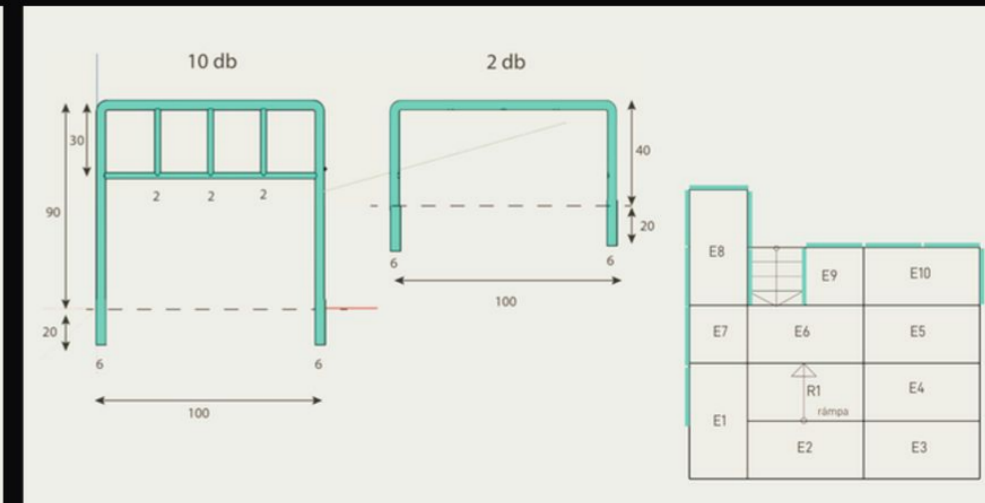
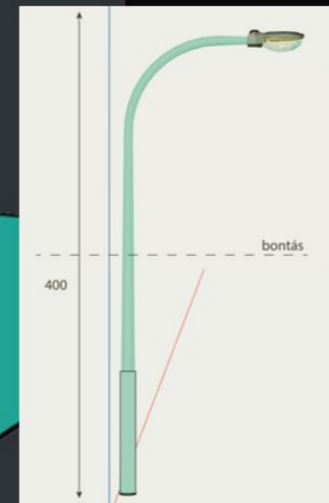
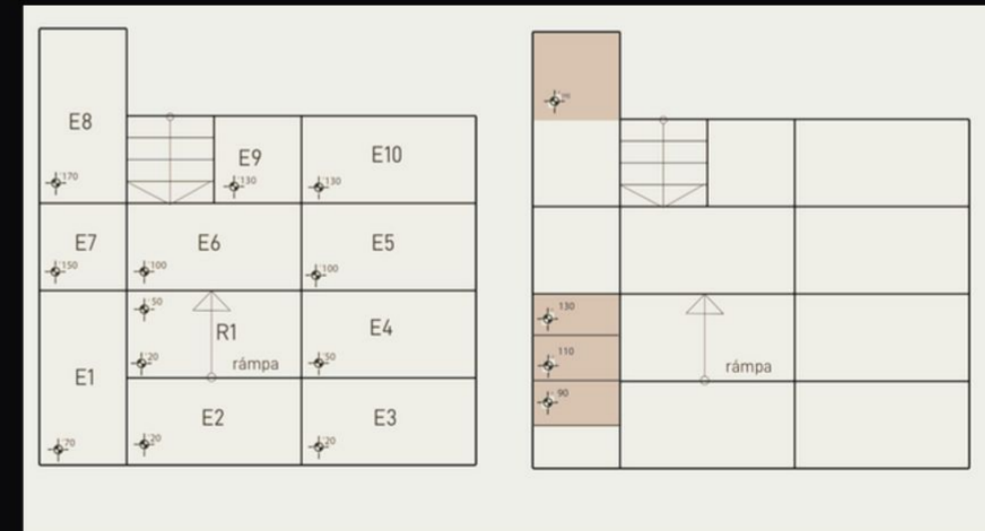
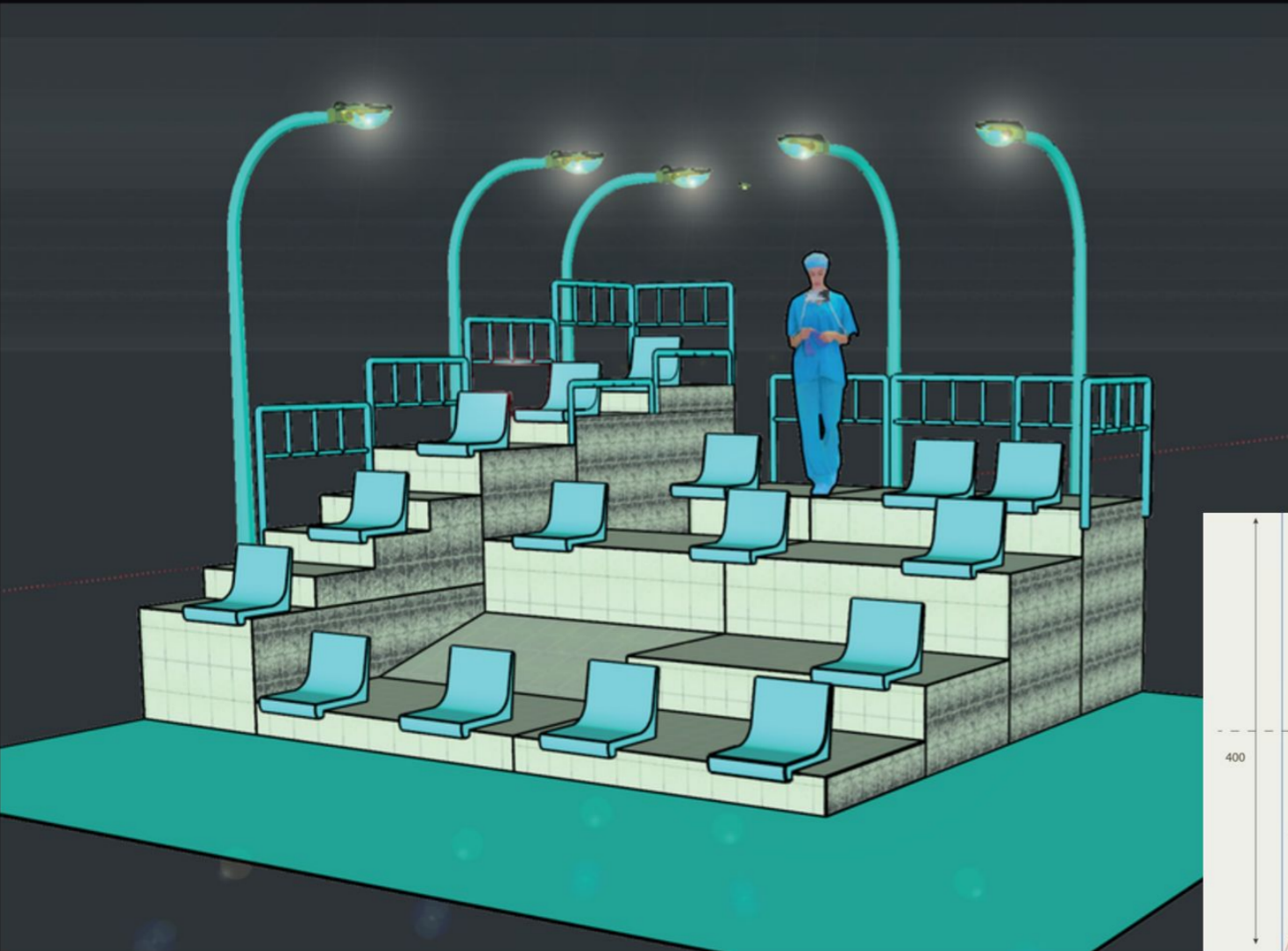

F. M. Dosztojevszkij: Bűn és bűnhődés_ Tatabányai
Jászai Mari Színház
Díszlet_2024

rendező: Hegymegi Máté

jelmeztervező: Szabados Luca

fénytervező: Gergely Erzsi

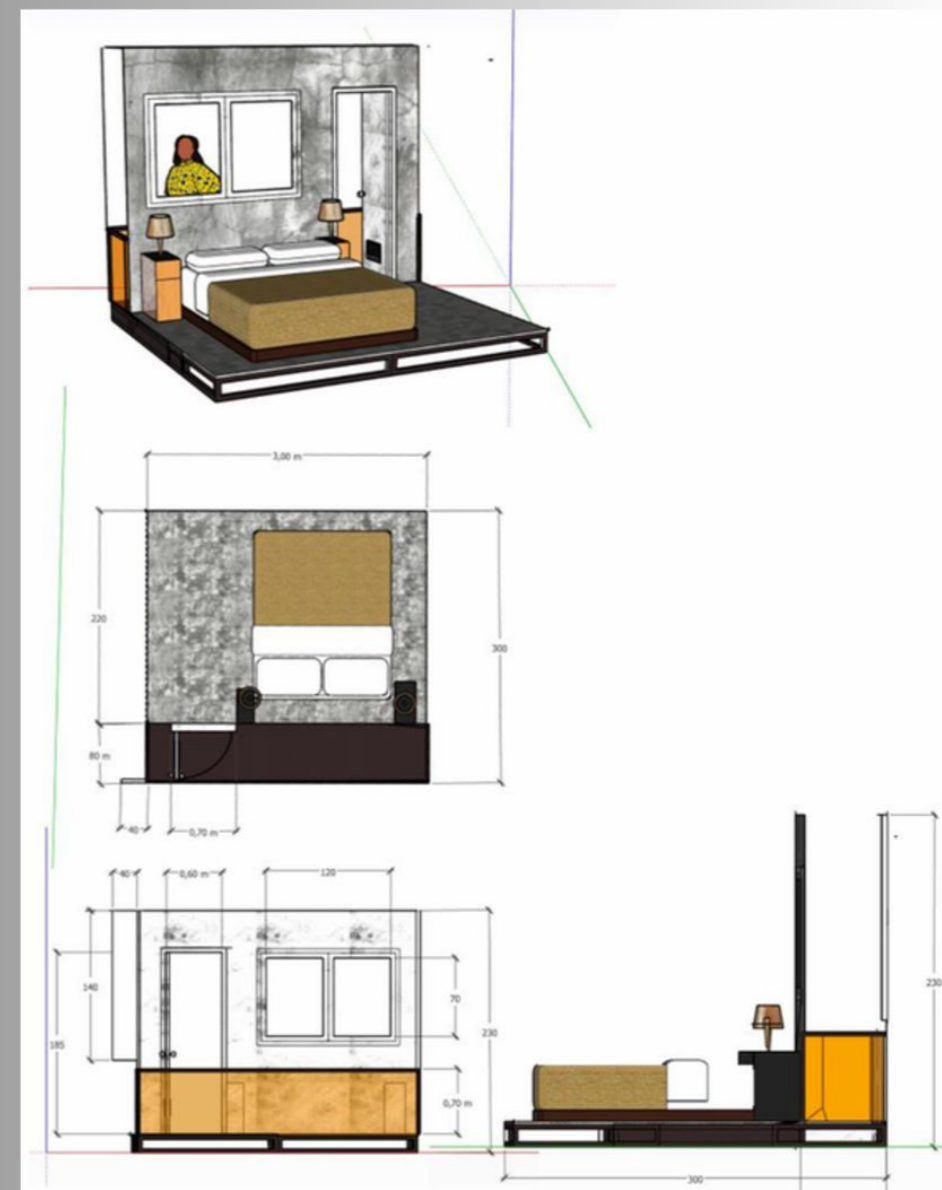

A Kiskondás_ Jurányi Ház
rendezés, díszlet/jelmez/ báb tervezés_2025

rendezte: Fekete Anna és Bánki Gergely

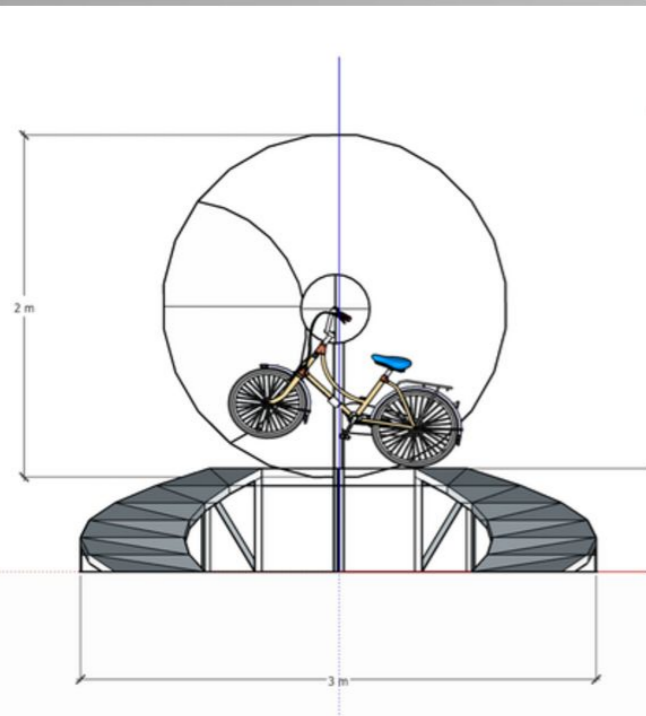
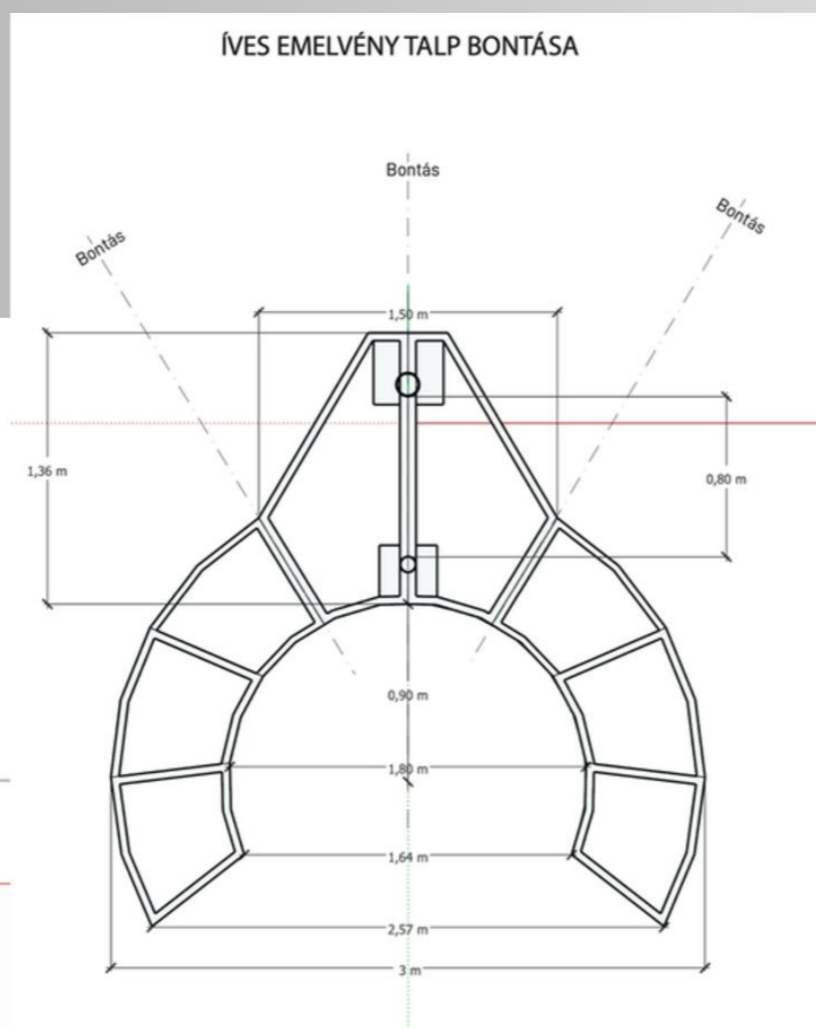

Otfried Preußler: Krabat a fekete malomban_
 Budapest Bábszínház Díszlet és báb tervezés_2024

rendezte : Hegymegi Máté
 jelmez: Kálmán Eszter
 fényterv: Szondi György

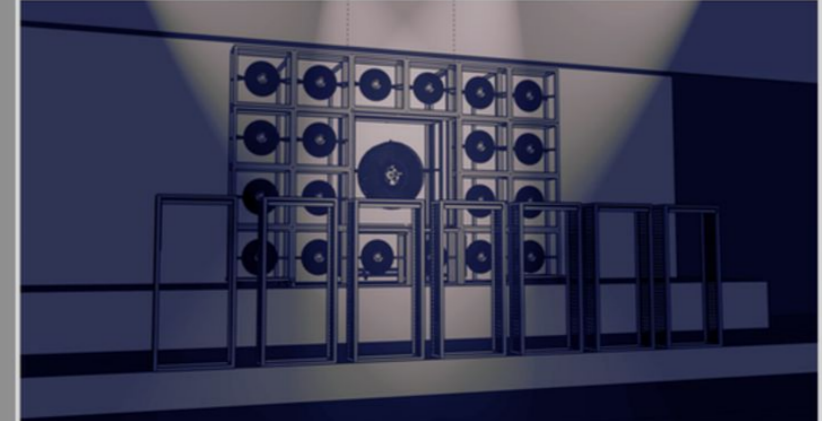
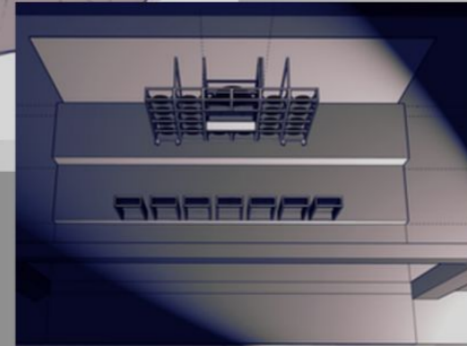
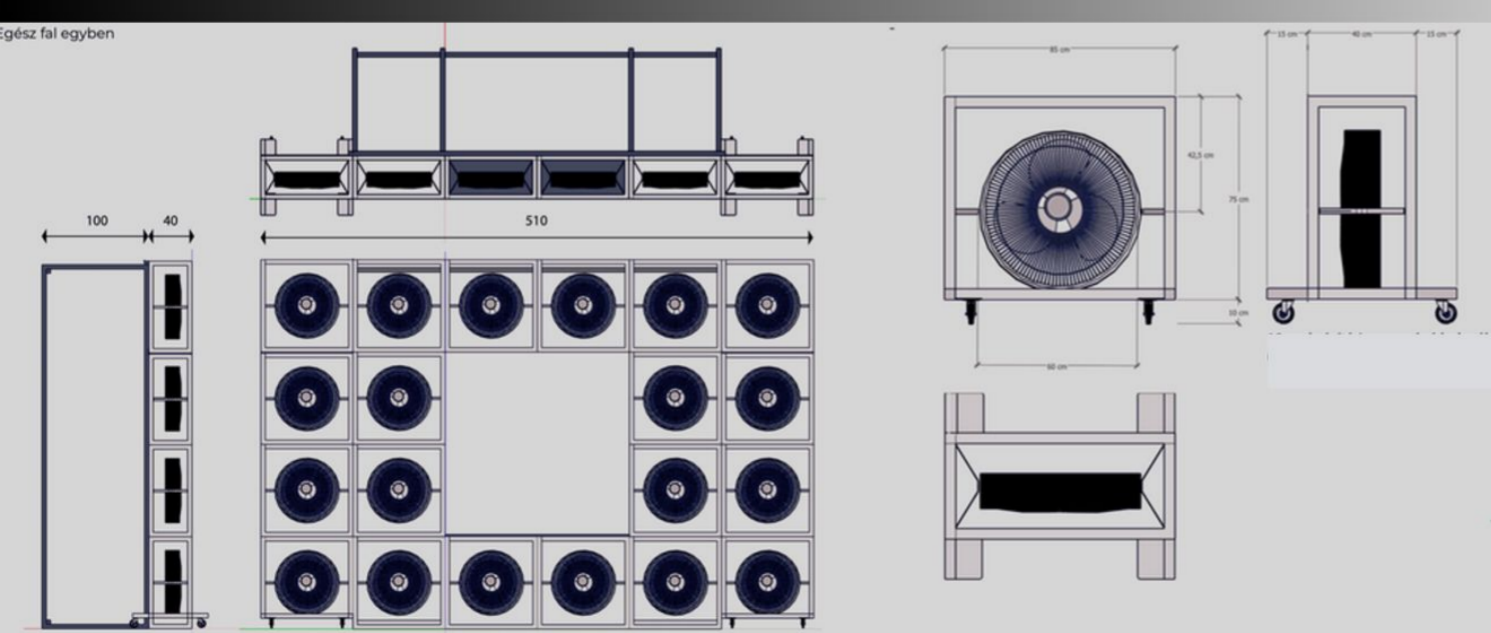
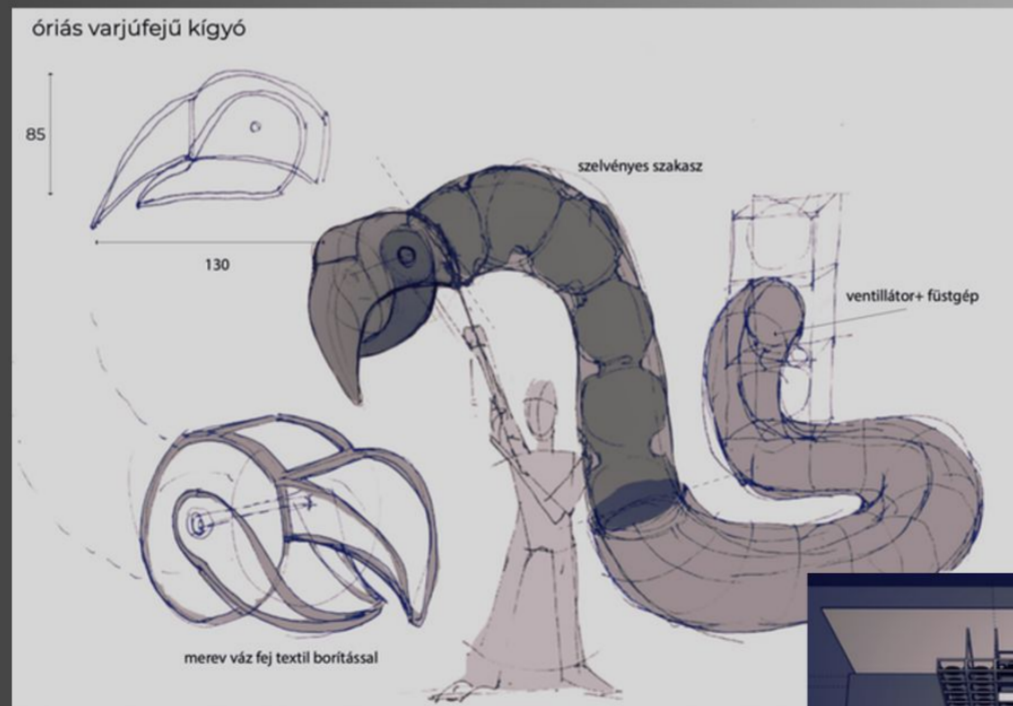

Glória_ Tatabányai Jászai Mari Színház
Díszlet_2024

rendezte : Guelmino Sándor
Jelmez: Kárpáti Enikő





Mindenki legyen kufli!_ Budapest Bábszínház Díszlet, jelmez és báb tervezés_2024

rendezte: Ellinger Edina
fényterv: Szondi György

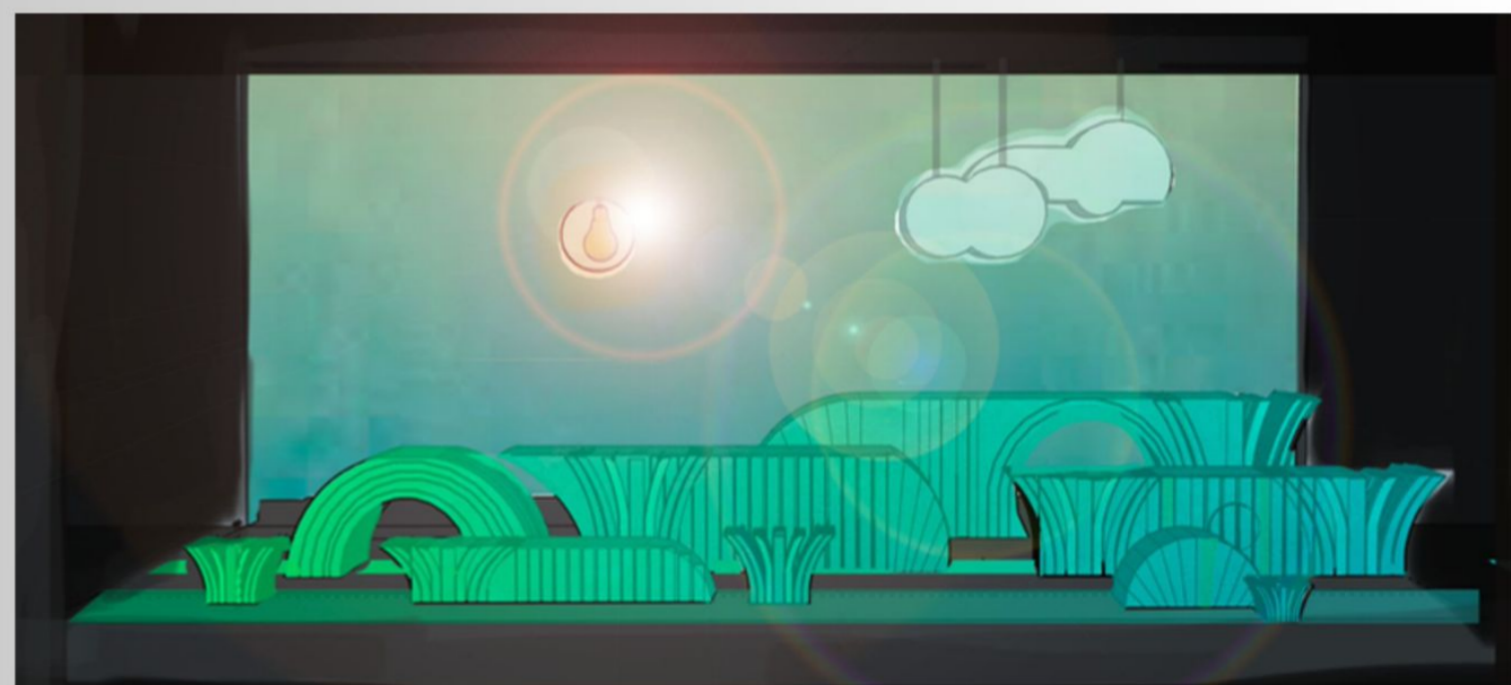
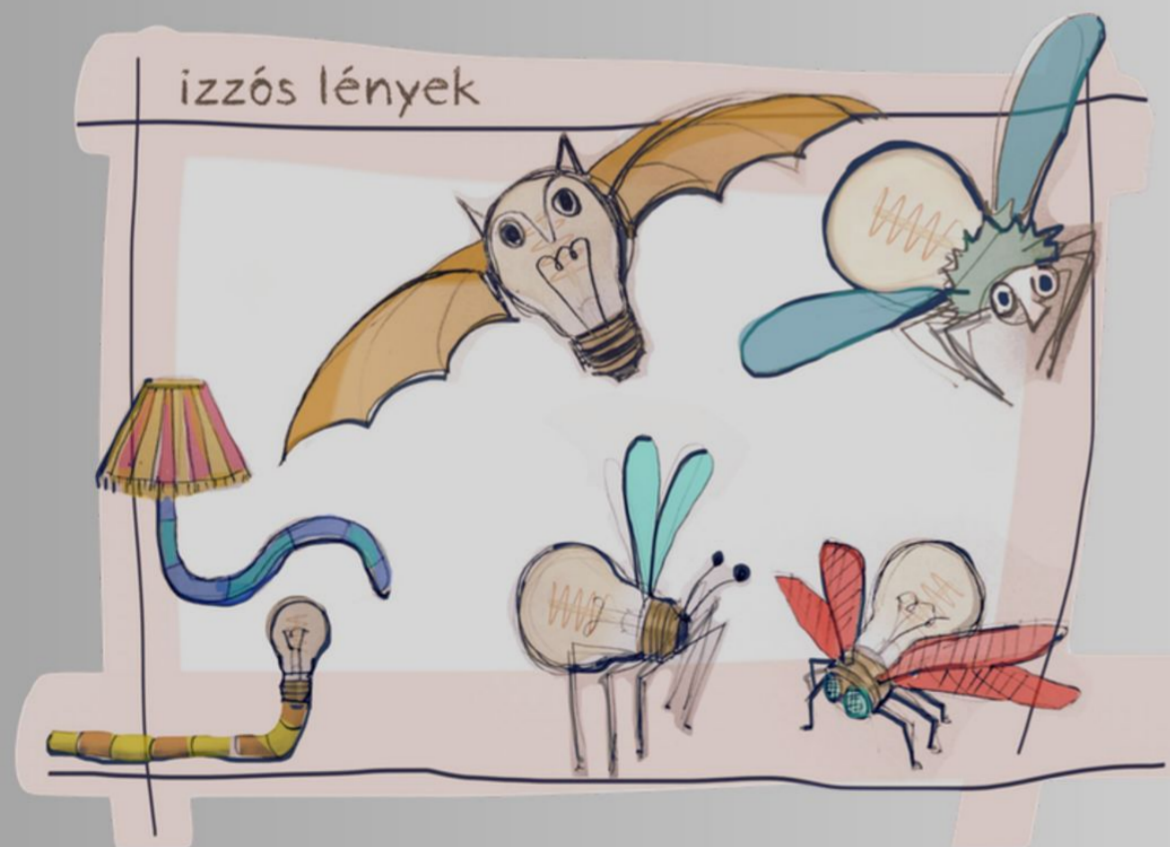

Julia Donaldson: A legcsinosabb óriás
Jurányi Ház
rendezés, díszlet /jelmez/ báb tervezés_2023
rendezte : Fekete Anna és Bánki Gergely

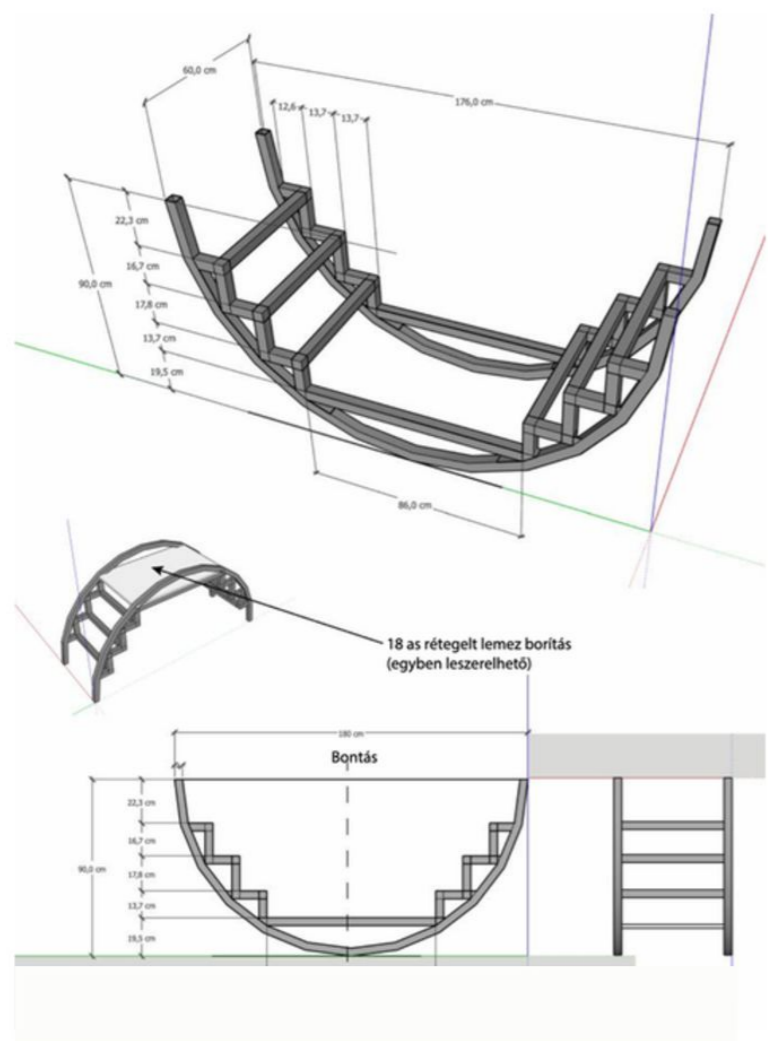

Néró_ Stúdió K Színház Díszlet_2020

rendezte: Hegymegi Máté
jelmez: Kálmán Eszter
fényterv: Berta Ninett, Hegymegi Máté

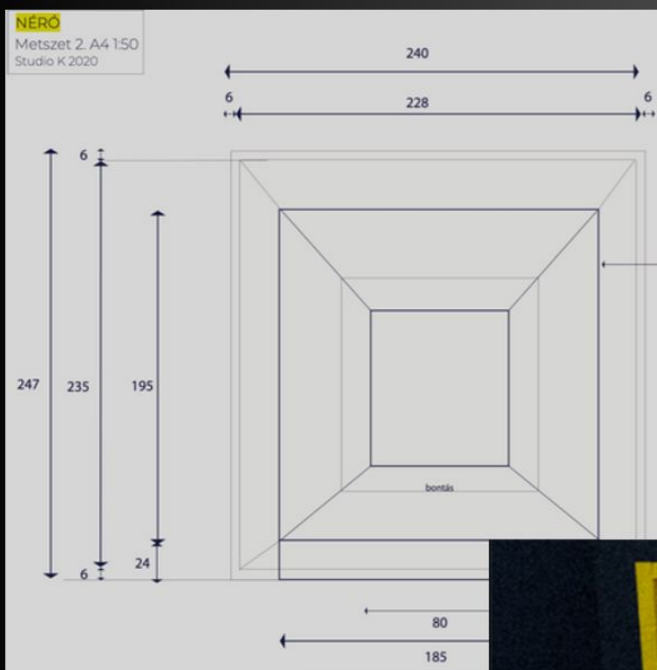
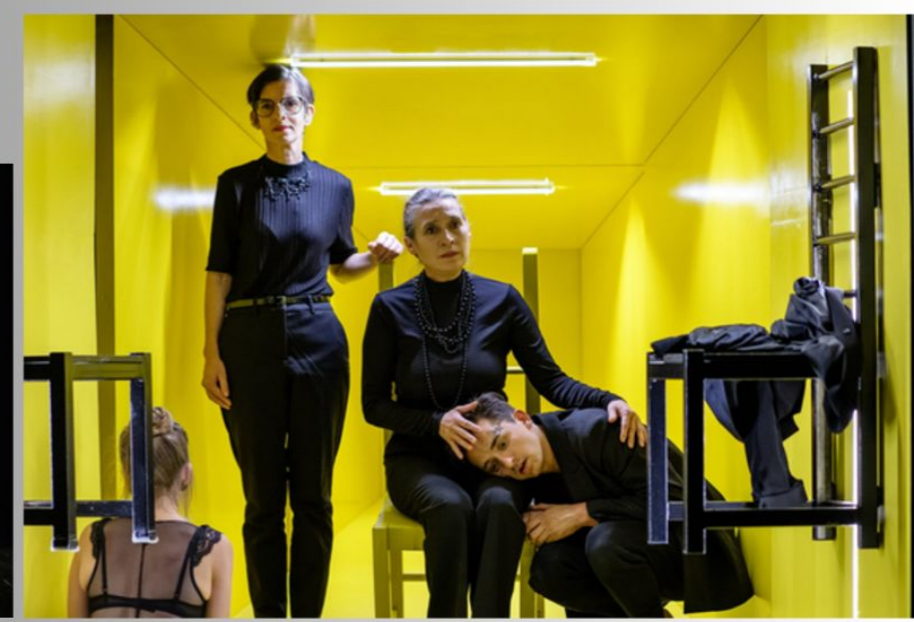

NÉRÓ_STUDIO K

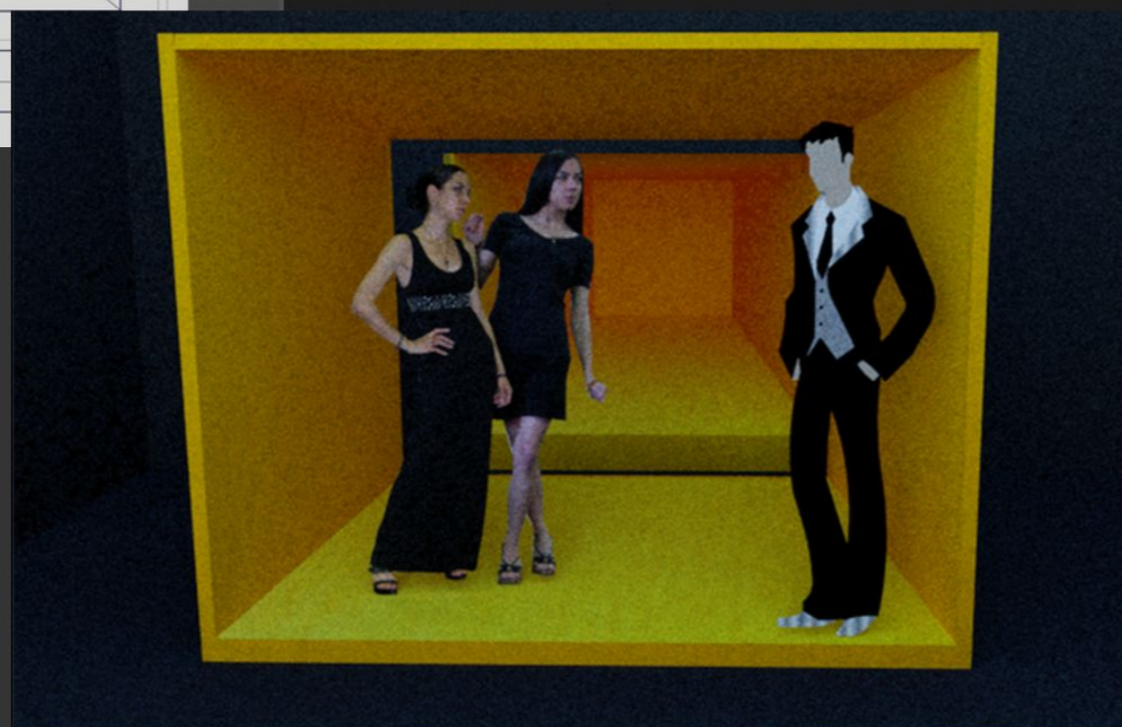
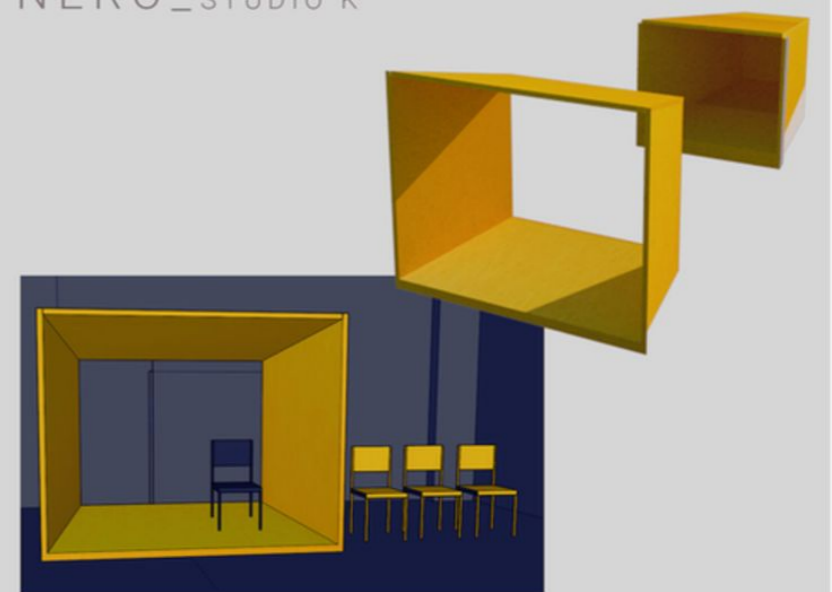

Molière the Passion_ Radnóti Színház

Díszlet _2020

rendezte: Hegymegi Máté

jelmez: Kálmán Eszter

fényterv: Bánya Tamás



MOLIÉRE ALAPRAJZ _ A4 1:100

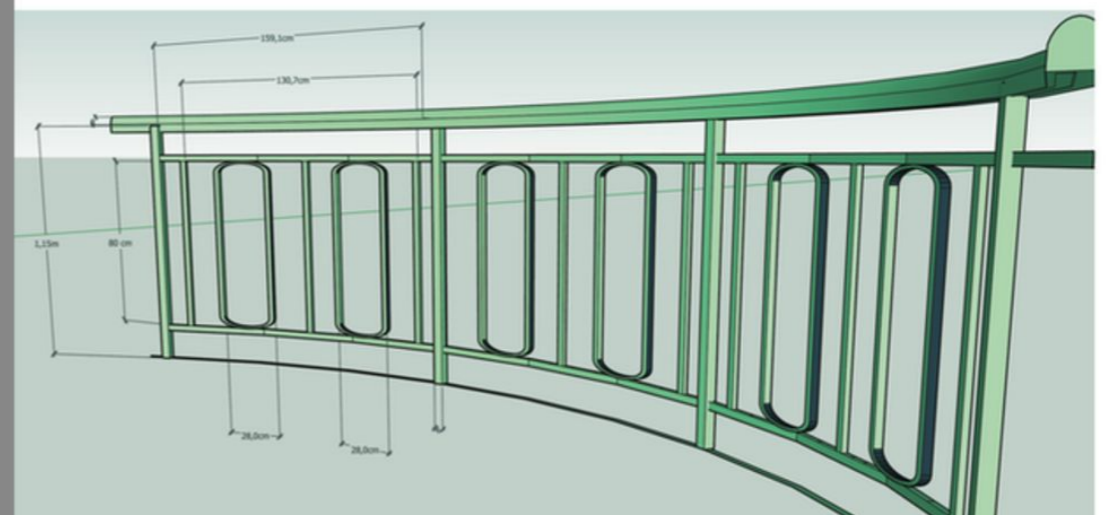
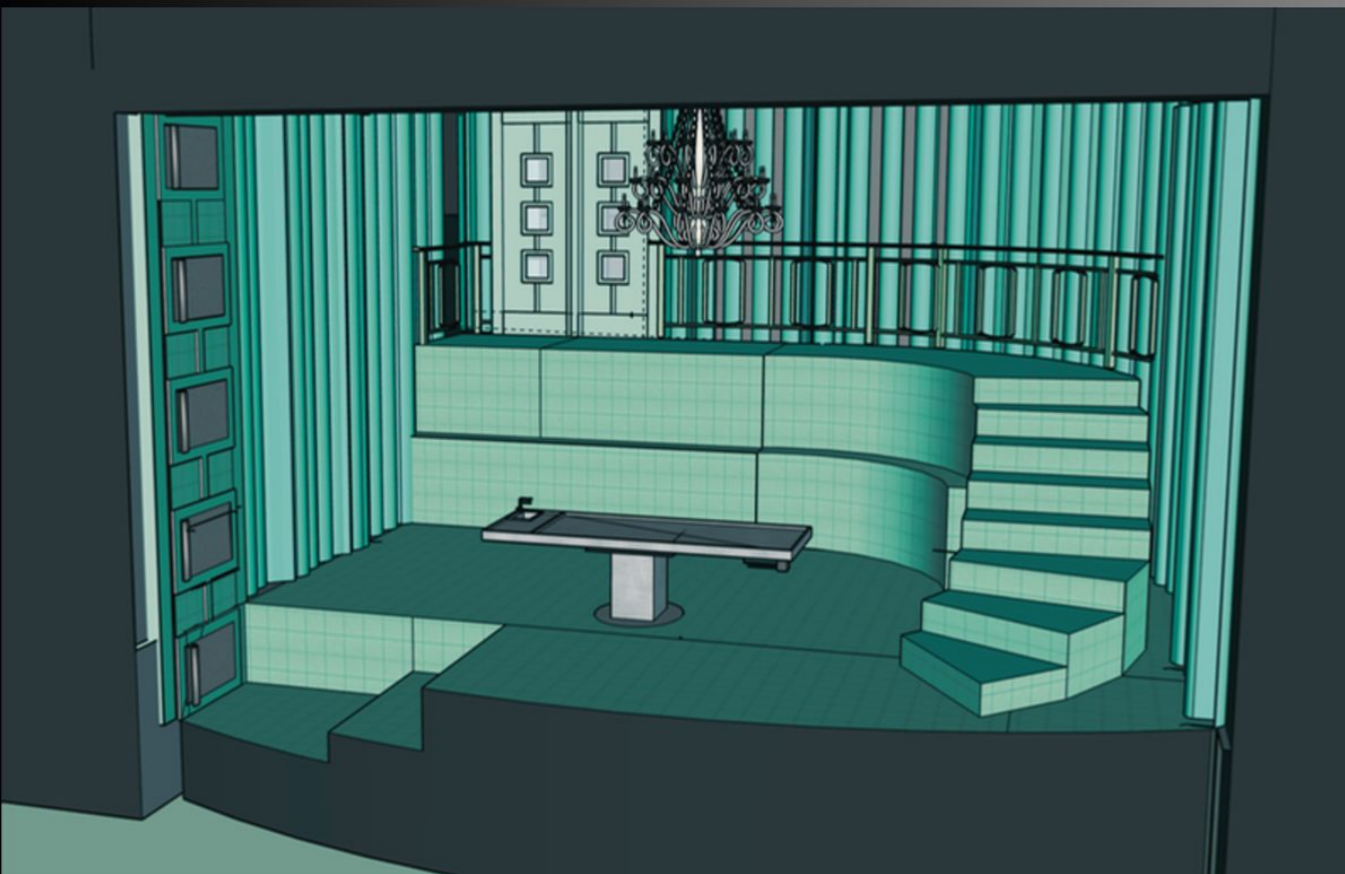
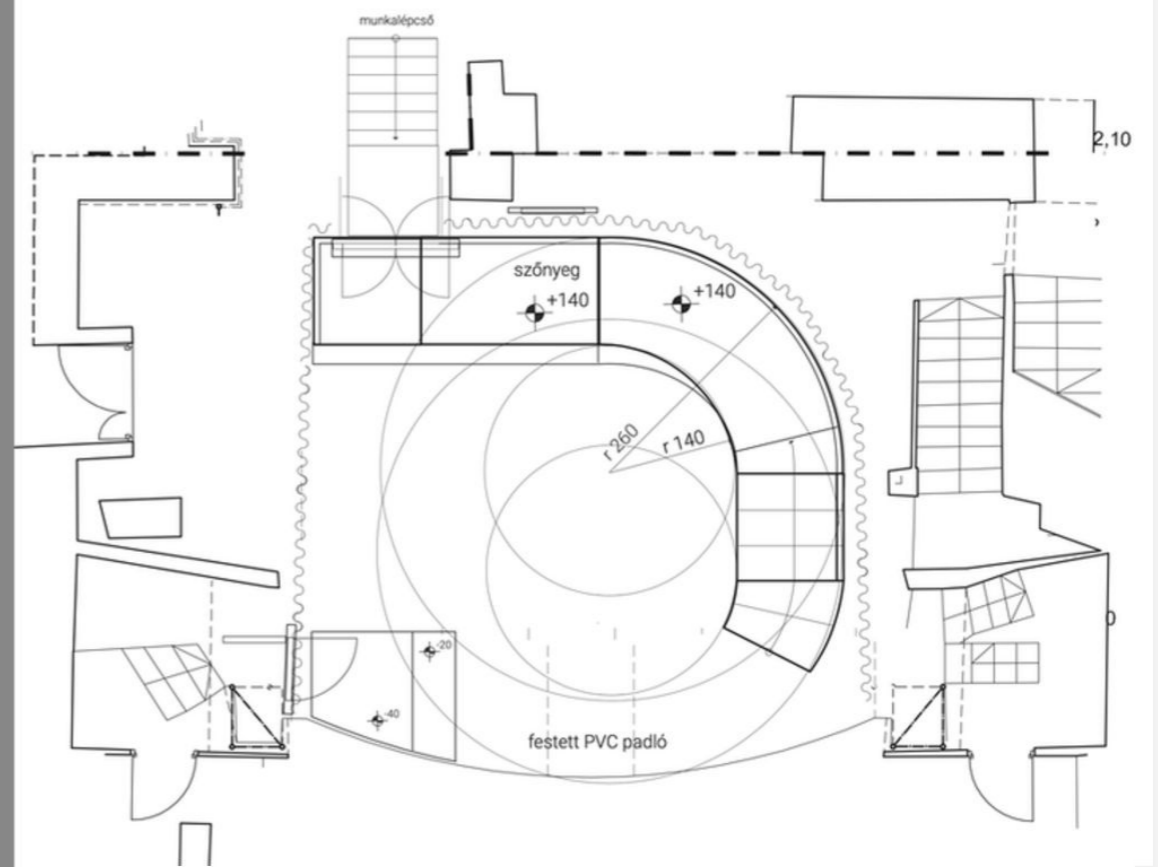

10_ Tatabányai Jászai Mari Színház

Díszlet_2021

rendezte : Guelmino Sándor

Jelmez: Kárpáti Enikő



HÁTSÓ FALAK BURKOLAT ERKÉLYEK



A legyek _ Örkény Isván Színház
Díszlet_2019

rendezte : Hegymegi Máté
jelmez: Kálmán Eszter
fényterv: Jankó Mátyás

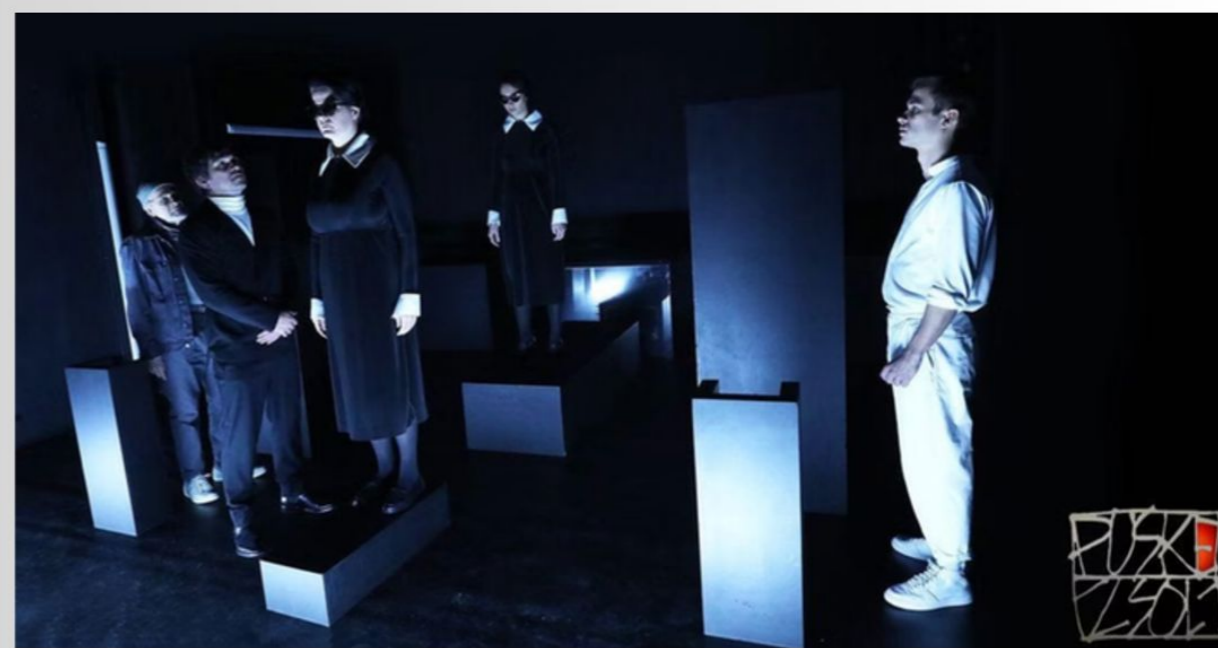
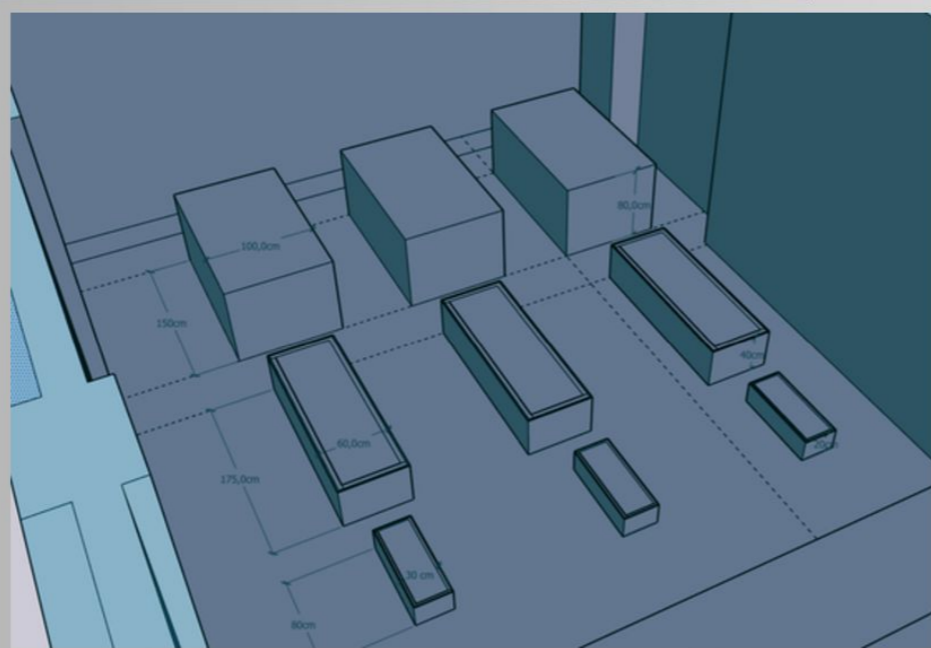
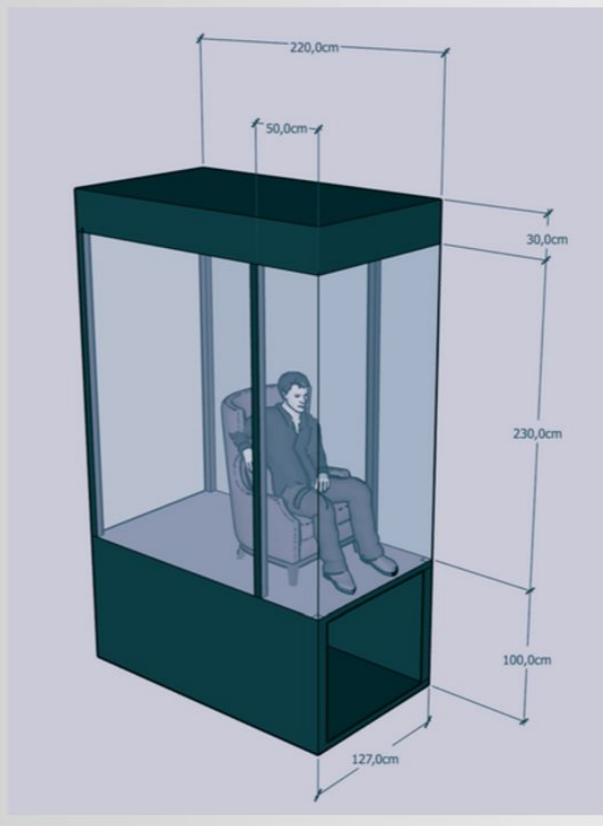

Jeanne d'Arc _ Katona József Színház
Díszlet_2019

rendezte : Hegymegi Máté
jelmez: Kálmán Eszter

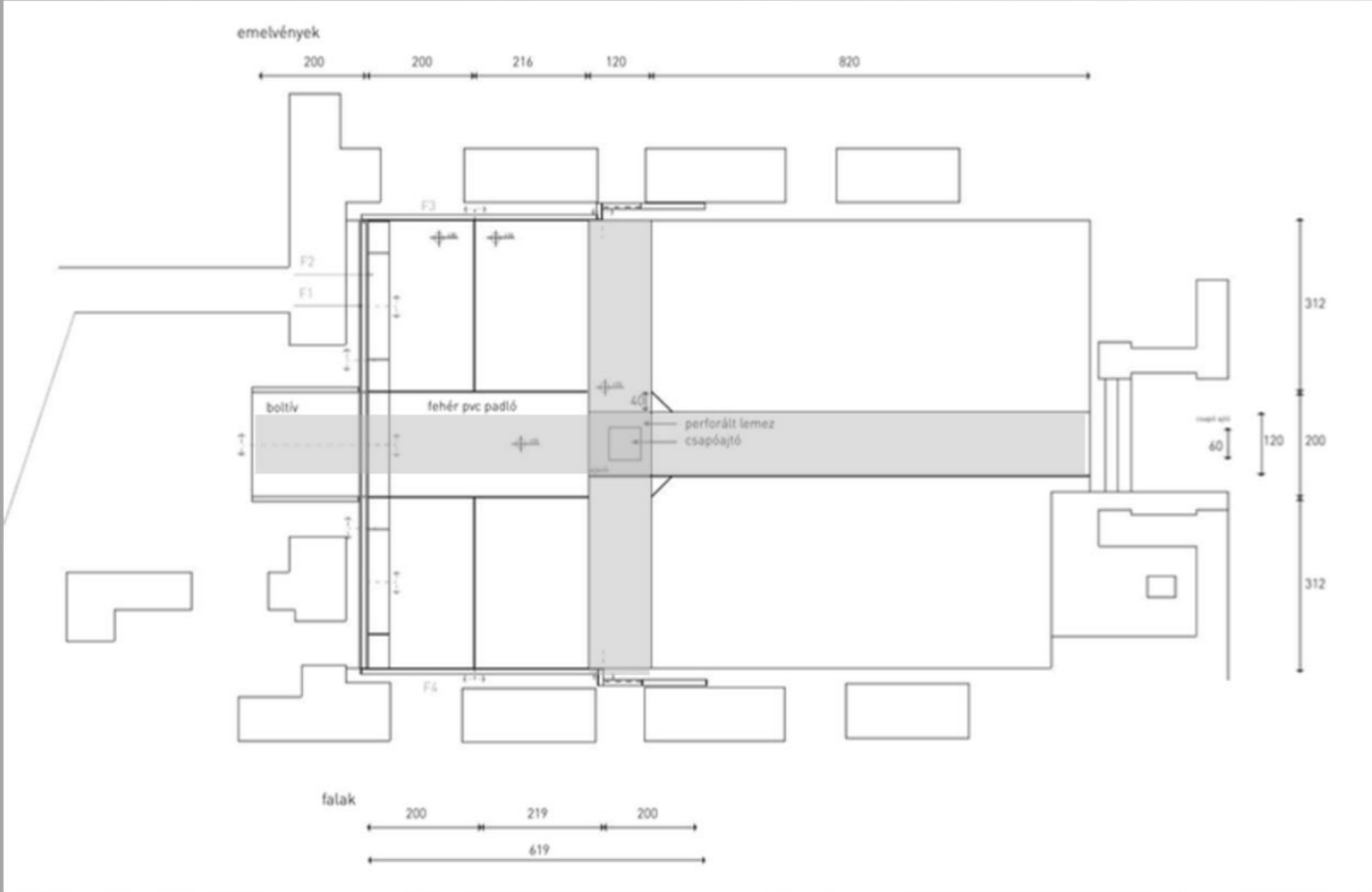

Egyenes labirintus _ Fővárosi Nagycirkusz Díszlet_2018

rendezte : Hegymegi Máté
jelmez: Kálmán Eszter

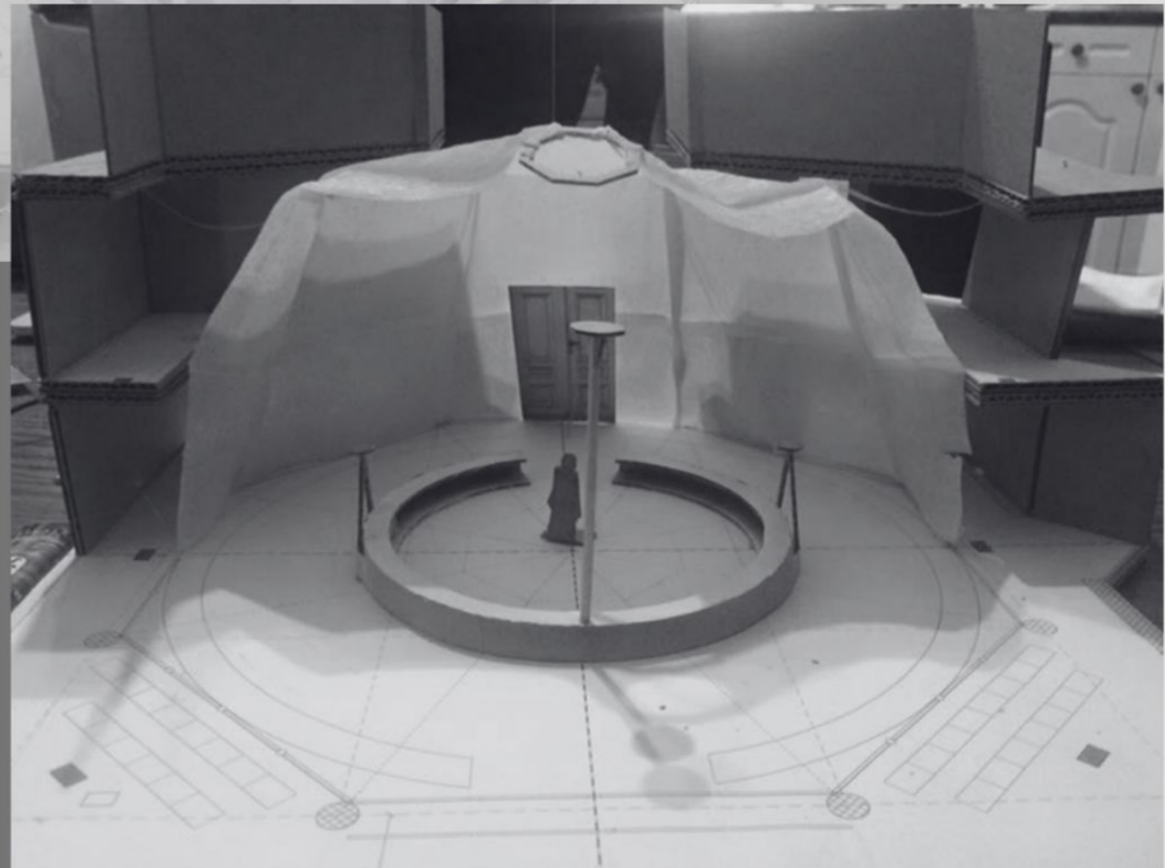
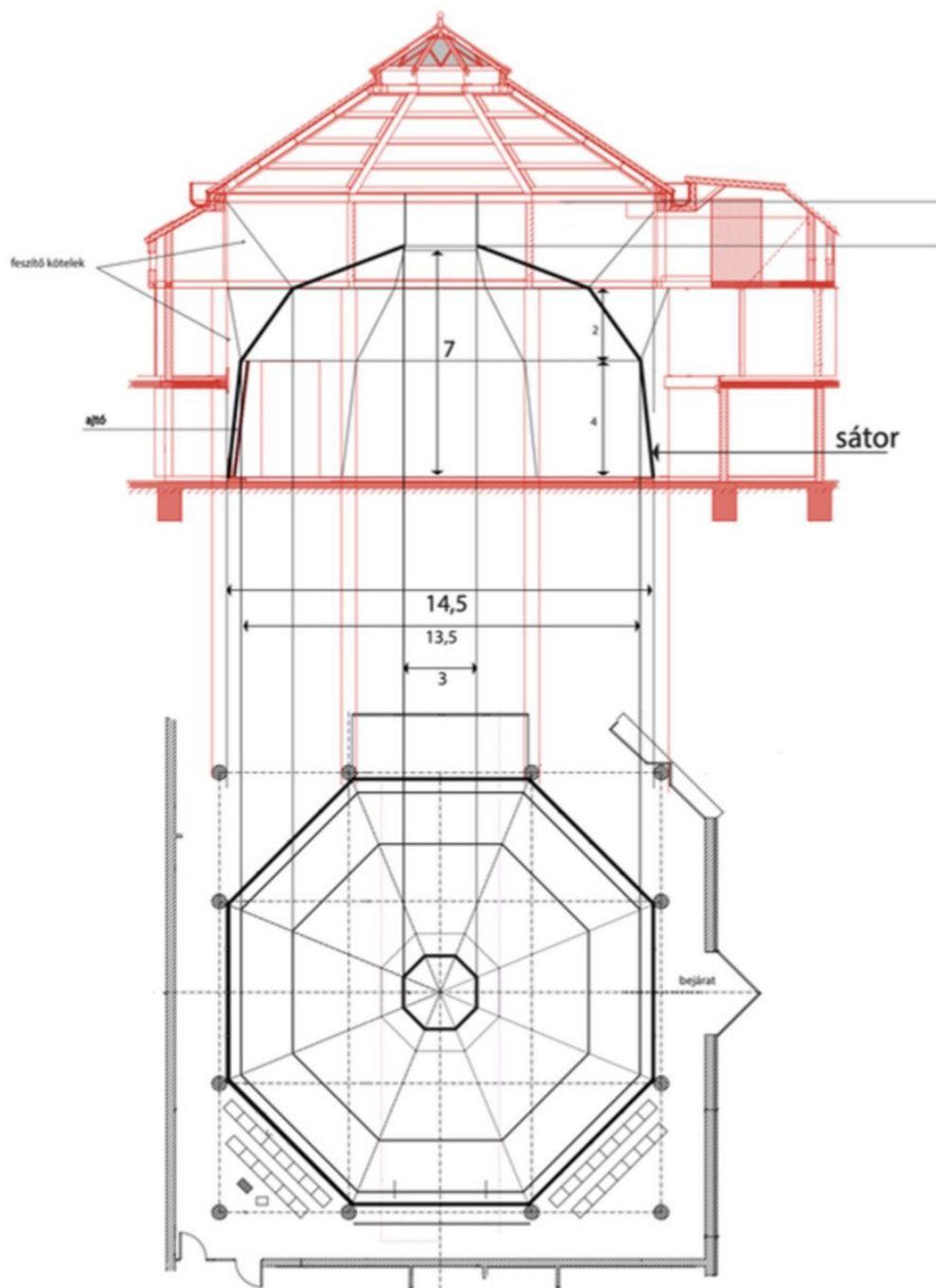

Bádogdob_ Katona József Színház
Díszlet_2016

rendezte : Hegymegi Máté
jelmez: Kálmán Eszter

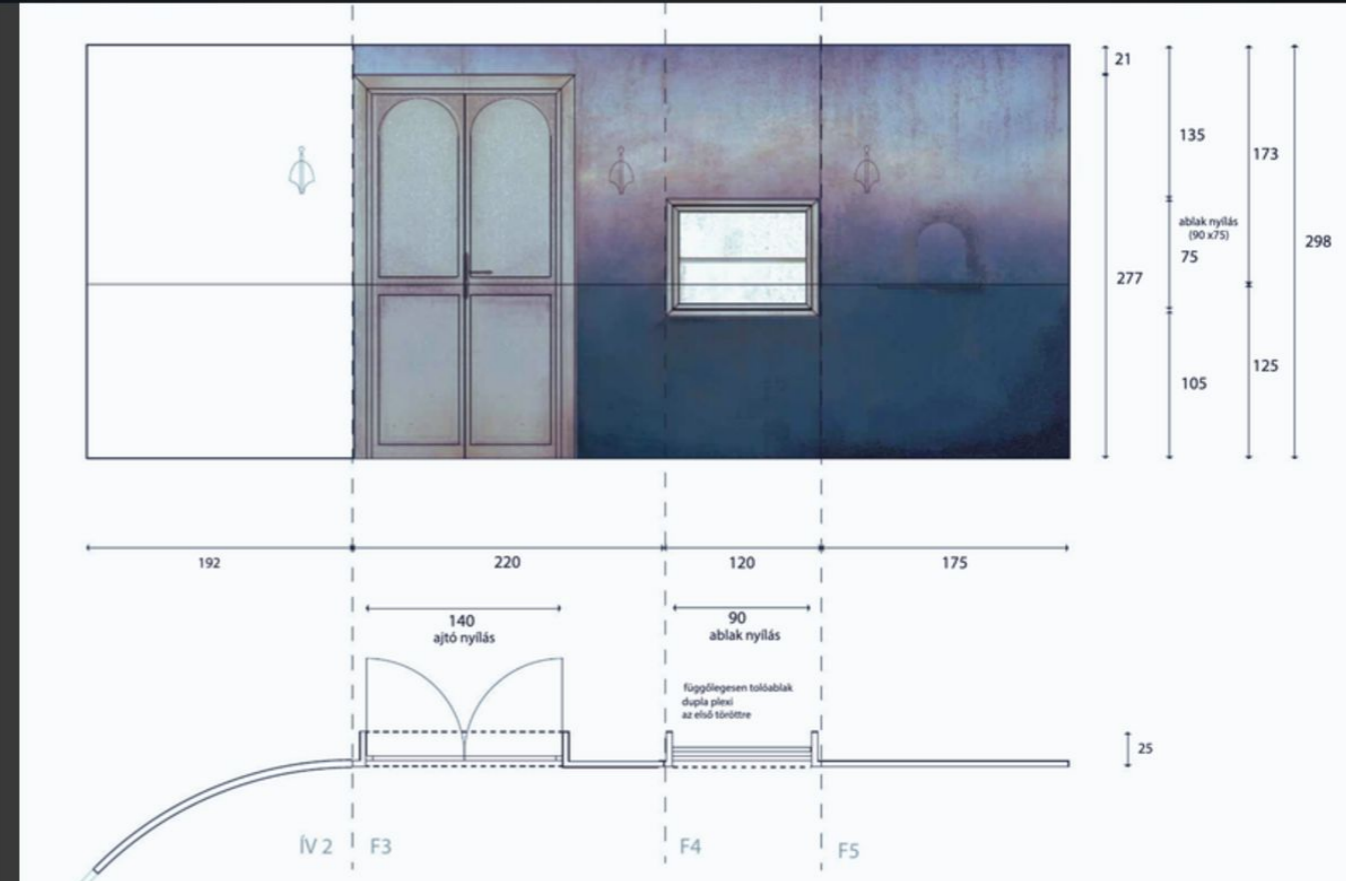
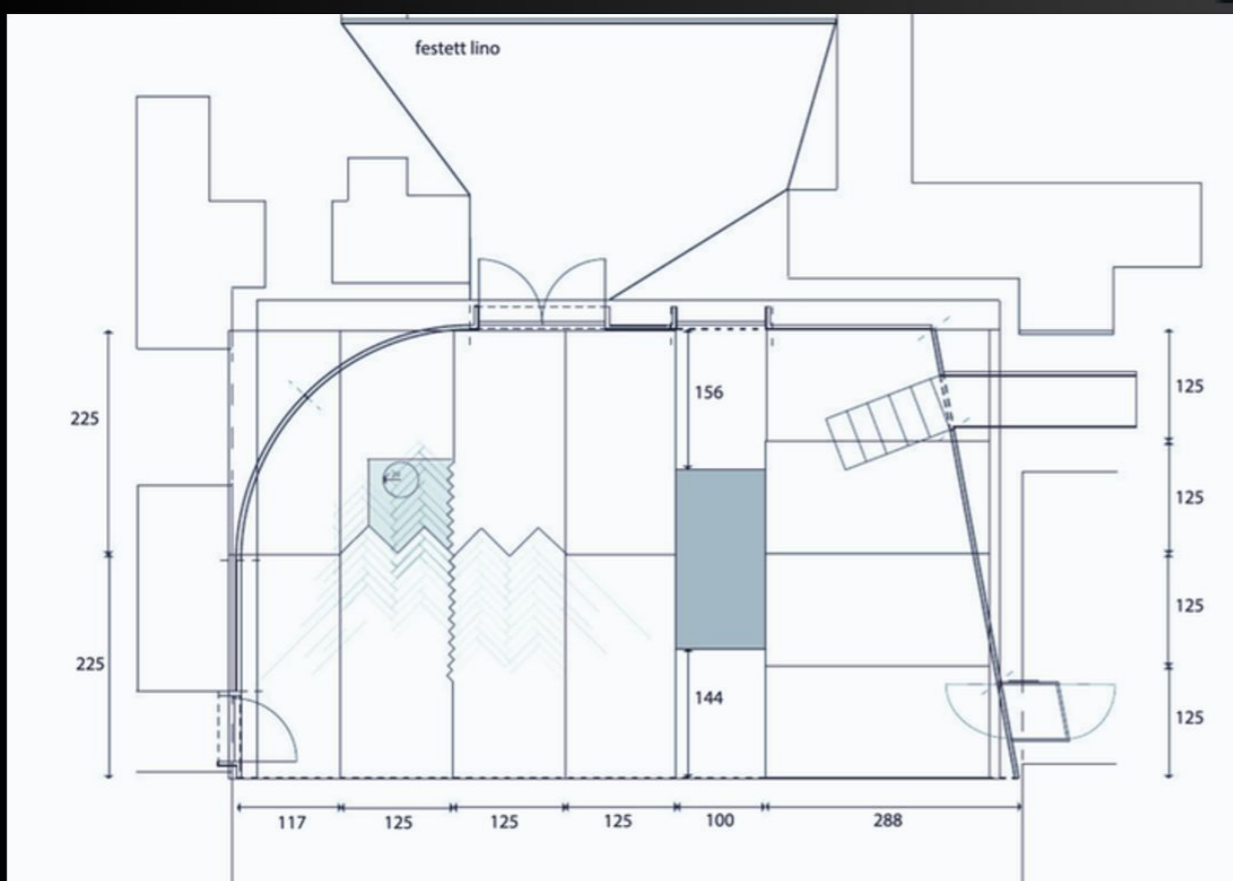

Kohlhaas_ Szkéné Színház
Díszlet_2015



rendezte : Hegymegi Máté
jelmez: Oláh Tímea
fényterv: Payer Ferenc

